

UniStream® Built-in

Technical Specifications

**US5-B5-TA32, US5-B10-TA32,
US5-C5-TA32, US5-C10-TA32**

**US7-B5-TA32, US7-B10-TA32,
US7-C5-TA32, US7-C10-TA32**

**US10-B5-TA32, US10-B10-TA32,
US10-C5-TA32, US10-C10-TA32**

Unitronics’ UniStream® Built-in series are PLC+HMI All-in-One programmable controllers that comprise built-in HMI and built-in I/Os.

UniStream connects directly to UniCloud, Unitronics' IIoT cloud platform using built-in UniCloud connectivity. More information about UniCloud is available at www.unitronics.cloud.

Model numbers in this document

US 5 - B 5 - TA32

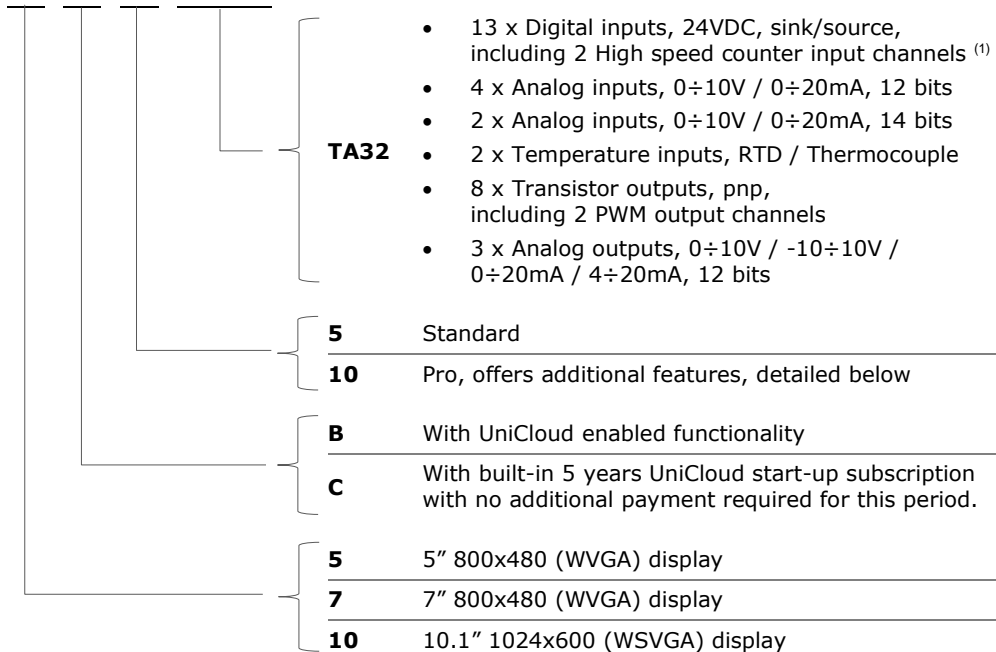

- 13 x Digital inputs, 24VDC, sink/source, including 2 High speed counter input channels ⁽¹⁾
- 4 x Analog inputs, 0÷10V / 0÷20mA, 12 bits
- 2 x Analog inputs, 0÷10V / 0÷20mA, 14 bits
- 2 x Temperature inputs, RTD / Thermocouple
- 8 x Transistor outputs, pnp, including 2 PWM output channels
- 3 x Analog outputs, 0÷10V / -10÷10V / 0÷20mA / 4÷20mA, 12 bits

Installation Guides are available in the Unitronics Technical Library at www.unitronicsplc.com.

Power Supply		
Input voltage	24VDC	
Permissible range	20.4VDC to 28.8VDC	
Max. current consumption	US5	0.44A@24VDC
	US7	0.53A@24VDC
	US10	0.56A@24VDC
Isolation	None	

Display	UniStream 5"	UniStream 7"	UniStream 10.1"
LCD type	TFT		
Backlight type	White LED		
Luminous intensity (brightness)	Typically 350 nits (cd/m ²), at 25°C	Typically 400 nits (cd/m ²), at 25°C	Typically 300 nits (cd/m ²), at 25°C
Backlight longevity ⁽²⁾	30k hours		
Resolution (pixels)	800 x 480 (WVGA)		1024 x 600 (WSVGA)
Size	5"	7"	10.1"
Viewing area	Width x Height (mm) 108 x 64.8	Width x Height (mm) 154.08 x 85.92	Width x Height (mm) 222.72 x 125.28
Color support	65,536 (16bit)		
Surface treatment	Anti-glare		
Touch screen	Resistive Analog		
Actuation force (min)	> 80 g (0.176 lb)		

General	
I/O support	Up to 2,048 I/O points
Built-in I/O	According to model
Local I/O expansion	To add local I/Os, use UAG-CX I/O Expansion Adapters ⁽³⁾ . These adapters provide the connection point for standard UniStream Uni-I/O™ modules. You can connect up to 80 I/O modules to a single controller using these adapters.
Remote I/O	Up to 8 UniStream Remote I/O Adapters (URB)
Communication ports	
Built-in COM ports	Specifications are provided below in the section Communications
Add-on Ports	Add up to 3 ports to a single controller using Uni-COM™ UAC-CX Modules ⁽⁴⁾ .
Internal memory	Standard (B5/C5)
	RAM: 512MB ROM: 3GB system memory 1GB user memory
	Pro (B10/C10)
	RAM: 1GB ROM: 6GB system memory 2GB user memory

Ladder memory	1 MB
External memory	microSD or microSDHC card Size: up to 32GB Data Speed: up to 200Mbps
Bit operation	0.13 μ s
Battery	Model: 3V CR2032 Lithium battery ⁽⁵⁾ Battery lifetime: 4 years typical, at 25°C Battery Low detection and indication (via the HMI and via System Tag).

Audio (Pro B10/C10 models only)

Bit Rate	192kbps
Audio compatibility	Stereo MP3 files
Interface	3.5mm Audio-out jack - use shielded audio cable of up to 3 m (9.84 ft)
Impedance	16 Ω , 32 Ω
Isolation	None

Video (Pro B10/C10 models only)

Supported Formats	MPEG-4 Visual , AVC/H.264
-------------------	---------------------------

Communication (Built-in Ports)

Ethernet port	
Number of ports	1
Port type	10/100 Base-T (RJ45)
Auto crossover	Yes
Auto negotiation	Yes
Isolation voltage	500VAC for 1 minute
Cable	Shielded CAT5e cable, up to 100 m (328 ft)
USB device ⁽⁶⁾	
Number of ports	1
Port type	Mini-B
Data rate	USB 2.0 (480Mbps)
Isolation	None
Cable	USB 2.0 compliant; < 3 m (9.84 ft)
USB host	
Number of ports	1
Port type	Type A
Data rate	USB 2.0 (480Mbps)
Isolation	None
Cable	USB 2.0 compliant; < 3 m (9.84 ft)
Over current protection	Yes

Digital Inputs	
Number of inputs	13
Type	Sink or Source
Isolation voltage	
Input to bus	500VAC for 1 minute
Input to input	None
Nominal voltage	I0-I8: 24VDC @ 6mA I9-I12: 24VDC @ 8mA
Input voltage	
Sink/Source	On state: 15-30VDC, 4mA min. Off state: 0-5VDC, 1mA max.
Nominal impedance	I0-I8: 4kΩ I9-I12: 3kΩ
Filter	I0-I8: 6ms typical I9-I12: 5.5μs, 50μs, 0.5ms, 6ms, 12ms
High speed inputs ⁽¹⁾	
Frequency / Period	Pulse/Direction mode: 90kHz max. / 11.1μs min (t_p in the Pulse/Dir Mode figure below). Quadrature mode: 80kHz max. / 12.5μs min (t_p in the Quadrature Mode figure below).
Pulse width	Pulse/Direction mode: 5.1μs min. for each state (t_w in Pulse/Dir Mode figure below). Quadrature mode: 2.5μs min. for each state (t_w in Quadrature Mode figure below).
Cable	Shielded twisted pair

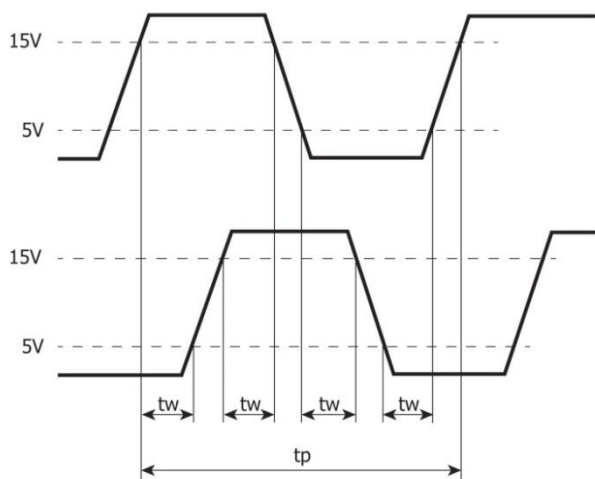

Quadrature Mode

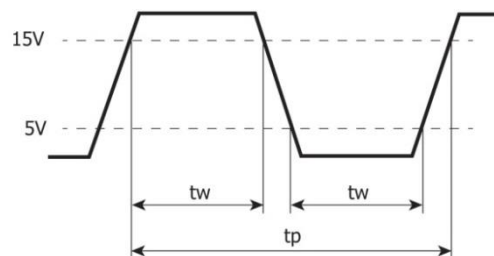

Pulse/Direction mode

Analog Inputs 0 to 3					
Number of inputs	4				
Input range ⁽⁷⁾ ⁽⁸⁾	Input Type	Nominal Values		Over-range Values *	
	0 ÷ 10VDC	0 ≤ Vin ≤ 10VDC		10 < Vin ≤ 10.15VDC	
	0 ÷ 20mA	0 ≤ Iin ≤ 20mA		20 < Iin ≤ 20.3mA	
	* Overflow ⁽⁹⁾ is declared when an input value exceeds the Over-range boundary.				
Absolute maximum rating	±30V (Voltage), ±30mA (Current)				
Isolation	None				
Conversion method	Successive approximation				
Resolution	12 bits				
Accuracy (25°C / -20°C to 55°C)	±0.3% / ±0.9% of full scale				
Input impedance	541kΩ (Voltage), 248Ω (Current)				
Noise rejection	10Hz, 50Hz, 60Hz, 400Hz				
Step response ⁽¹⁰⁾ (0 to 100% of final value)	Smoothing	Noise Rejection Frequency			
		400Hz	60Hz	50Hz	10Hz
	None	2.7ms	16.86ms	20.2ms	100.2ms
	Weak	10.2ms	66.86ms	80.2ms	400.2ms
	Medium	20.2ms	133.53ms	160.2ms	800.2ms
Strong	40.2ms	266.86ms	320.2ms	1600.2ms	
Update time ⁽¹⁰⁾	Noise Rejection Frequency		Update Time		
	400Hz		5ms		
	60Hz		4.17ms		
	50Hz		5ms		
	10Hz		10ms		
Operational signal range (signal + common mode)	Voltage mode – AIX: -1V ÷ 10.5V ; CM1: -1V ÷ 0.5V Current mode – AIX: -1V ÷ 5.5V ; CM1: -1V ÷ 0.5V (x=0 or 1)				
Cable	Shielded twisted pair				
Diagnostics ⁽⁹⁾	Analog input overflow				

Analog Inputs 5 to 6					
Number of inputs	2				
Input range ⁽⁷⁾ ⁽⁸⁾	Input Type	Nominal Values		Over-range Values *	
	0 ÷ 10VDC	0 ≤ Vin ≤ 10VDC		10 < Vin ≤ 10.15VDC	
	0 ÷ 20mA	0 ≤ Iin ≤ 20mA		20 < Iin ≤ 20.3mA	
	* Overflow ⁽⁹⁾ is declared when an input value exceeds the Over-range boundary.				
Absolute maximum rating	±30V (Voltage), ±30V (Current)				
Isolation voltage					
Input to bus	500VAC for 1 minute				
Input to input	None				
Input to temperature inputs	None				
Conversion method	Delta-sigma				
Resolution	14 bits				
Accuracy (25°C / -20°C to 55°C)	±0.2% / ±0.5% of full scale (Voltage) ±0.2% / ±0.3% of full scale (Current)				
Input impedance	527kΩ (Voltage), 60.4Ω (Current)				
Noise rejection	10Hz, 50Hz, 60Hz, 400Hz				
Step response ⁽¹⁰⁾ (0 to 100% of final value)	Smoothing	Noise Rejection Frequency			
		400Hz	60Hz	50Hz	10Hz
	None	162.4ms	249.5ms	249.5ms	1242.4ms
	Weak	317.3ms	491.5ms	491.5ms	2477.3ms
	Medium	627.2ms	975.4ms	975.4ms	4947ms
Strong	1246.9ms	1943.3ms	1943.3ms	9886.5ms	
Update time ⁽¹⁰⁾	Noise Rejection Frequency		Update Time		
	400Hz		154.9ms		
	60Hz		242ms		
	50Hz		242ms		
	10Hz		1234.9ms		
Cable	Shielded twisted pair				
Diagnostics ⁽¹¹⁾	Analog input overflow				

Temperature Inputs			
Number of inputs	2		
Sensor Type	RTD (4, 3 and 2 wire ⁽¹²⁾), Thermocouple		
Input range ⁽¹³⁾	Input type	Nominal values	Over/Under-range Values *
	RTD PT100 0.00385 0.00392 0.00391 PT1000 0.00385 0.00392	-200°C ≤ T ≤ 850°C (-328°F ≤ T ≤ 1,562°F)	Under-range: -220°C ≤ T < -200°C (-364°F ≤ T < -328°F) Over-range: 850°C < T ≤ 860°C (1,562°F < T ≤ 1,580°F)
	RTD NI100 0.00618 NI1000 0.00618	-100°C ≤ T ≤ 260°C (-148°F ≤ T ≤ 500°F)	Under-range: -150°C ≤ T < -100°C (-238°F ≤ T < -148°F) Over-range: 260°C < T ≤ 270°C (500°F < T ≤ 518°F)
	RTD NI120 0.00672	-80°C ≤ T ≤ 260°C (-112°F ≤ T ≤ 500°F)	Under-range: -130°C ≤ T < -80°C (-202°F ≤ T < -112°F) Over-range: 260°C < T ≤ 270°C (500°F < T ≤ 518°F)
	RTD NI100 0.00617	-60°C ≤ T ≤ 180°C (-76°F ≤ T ≤ 356°F)	Under-range: -104°C ≤ T < -60°C (-219°F ≤ T < -76°F) Over-range: 180°C < T ≤ 210°C (356°F < T ≤ 410°F)
	RTD NI1000 LG	-50°C ≤ T ≤ 190°C (-58°F ≤ T ≤ 374°F)	Under-range: -60°C ≤ T < -50°C (-76°F ≤ T < -58°F) Over-range: 190°C < T ≤ 200°C (374°F < T ≤ 392°F)
	Thermocouple type J	-200°C ≤ T ≤ 1,200°C (-328°F ≤ T ≤ 2,192°F)	Under-range: -210°C ≤ T < -200°C (-346°F ≤ T < -328°F) Over-range: 1,200°C < T ≤ 1,250°C (2,192°F < T ≤ 2,282°F)
	Thermocouple type K	-200°C ≤ T ≤ 1,372°C (-328°F ≤ T ≤ 2,501.6°F)	Under-range: -270°C ≤ T < -200°C (-454°F ≤ T < -328°F) Over-range: 1,372°C < T ≤ 1,400°C (2,501.6°F < T ≤ 2,552°F)

Thermocouple type T	$-200^{\circ}\text{C} \leq T \leq 400^{\circ}\text{C}$ ($-328^{\circ}\text{F} \leq T \leq 752^{\circ}\text{F}$)	Under-range: $-270^{\circ}\text{C} \leq T < -200^{\circ}\text{C}$ ($-454^{\circ}\text{F} \leq T < -328^{\circ}\text{F}$) Over-range: $400^{\circ}\text{C} < T \leq 430^{\circ}\text{C}$ ($752^{\circ}\text{F} < T \leq 806^{\circ}\text{F}$)
Thermocouple type E	$-200^{\circ}\text{C} \leq T \leq 1,000^{\circ}\text{C}$ ($-328^{\circ}\text{F} \leq T \leq 1,832^{\circ}\text{F}$)	Under-range: $-270^{\circ}\text{C} \leq T < -200^{\circ}\text{C}$ ($-454^{\circ}\text{F} \leq T < -328^{\circ}\text{F}$) Over-range: $1,000^{\circ}\text{C} < T \leq 1,010^{\circ}\text{C}$ ($1,832^{\circ}\text{F} < T \leq 1,850^{\circ}\text{F}$)
Thermocouple type R	$0^{\circ}\text{C} \leq T \leq 1,768^{\circ}\text{C}$ ($32^{\circ}\text{F} \leq T \leq 3,214.4^{\circ}\text{F}$)	Under-range: $-50^{\circ}\text{C} \leq T < 0^{\circ}\text{C}$ ($-58^{\circ}\text{F} \leq T < 32^{\circ}\text{F}$) Over-range: $1,768^{\circ}\text{C} < T \leq 1,800^{\circ}\text{C}$ ($3,214.4^{\circ}\text{F} < T \leq 3,272^{\circ}\text{F}$)
Thermocouple type S	$0^{\circ}\text{C} \leq T \leq 1,768^{\circ}\text{C}$ ($32^{\circ}\text{F} \leq T \leq 3,214.4^{\circ}\text{F}$)	Under-range: $-50^{\circ}\text{C} \leq T < 0^{\circ}\text{C}$ ($-58^{\circ}\text{F} \leq T < 32^{\circ}\text{F}$) Over-range: $1,768^{\circ}\text{C} < T \leq 1,800^{\circ}\text{C}$ ($3,214.4^{\circ}\text{F} < T \leq 3,272^{\circ}\text{F}$)
Thermocouple type B	$200^{\circ}\text{C} \leq T \leq 1,820^{\circ}\text{C}$ ($392^{\circ}\text{F} \leq T \leq 3,308^{\circ}\text{F}$)	Under-range: $100^{\circ}\text{C} \leq T < 200^{\circ}\text{C}$ ($212^{\circ}\text{F} \leq T < 392^{\circ}\text{F}$) Over-range: $1,820^{\circ}\text{C} < T \leq 1,870^{\circ}\text{C}$ ($3,308^{\circ}\text{F} < T \leq 3,398^{\circ}\text{F}$)
Thermocouple type N	$-210^{\circ}\text{C} \leq T \leq 1,300^{\circ}\text{C}$ ($-346^{\circ}\text{F} \leq T \leq 2,372^{\circ}\text{F}$)	Under range: $-270^{\circ}\text{C} \leq T < -210^{\circ}\text{C}$ ($-454^{\circ}\text{F} \leq T < -346^{\circ}\text{F}$) Over-range: $1,300^{\circ}\text{C} < T \leq 1,350^{\circ}\text{C}$ ($2,372^{\circ}\text{F} < T \leq 2,462^{\circ}\text{F}$)
Thermocouple type C	$10^{\circ}\text{C} \leq T \leq 2,315^{\circ}\text{C}$ ($50^{\circ}\text{F} \leq T \leq 4,199^{\circ}\text{F}$)	Under-range: $0^{\circ}\text{C} \leq T < 10^{\circ}\text{C}$ ($32^{\circ}\text{F} \leq T < 50^{\circ}\text{F}$) Over-range: $2,315^{\circ}\text{C} < T \leq 2,370^{\circ}\text{C}$ ($4,199^{\circ}\text{F} < T \leq 4,298^{\circ}\text{F}$)
Resistance	$0\Omega \leq R \leq 390\Omega$	$390\Omega < R \leq 395.85\Omega$
mV	$-70\text{mV} \leq V \leq 70\text{mV}$	Under-range: $-71.05\text{mV} \leq V < -70\text{mV}$ Over-range: $70\text{mV} \leq V < 71.05\text{mV}$
* Overflow or Underflow ⁽¹¹⁾ is declared when an input value exceeds the Over-range or Under-range boundaries respectively.		

Absolute maximum rating	±9 V				
RTD Maximum excitation current	0.26mA				
Isolation voltage					
Input to bus	500 VAC for 1 minute				
Input to input	None				
Input to analog inputs	None				
Conversion method	Delta-sigma				
Resolution	Temperature – 0.1°C (0.1°F) ⁽¹⁴⁾ Resistance – 14 bits mV – 13 bits plus sign				
Accuracy (25°C / -20°C to 55°C)	Input type	Accuracy			
	RTD, all types	± 0.5°C / ± 1.0°C (± 0.9°F / ± 1.8°F)			
	Thermocouple type J ⁽¹⁵⁾	± 0.4°C / ± 0.7°C (± 0.72°F / ± 1.26°F)			
	Thermocouple type K ⁽¹⁵⁾	± 0.5°C / ± 1.0°C (± 0.9°F / ± 1.8°F)			
	Thermocouple type T ⁽¹⁵⁾	± 0.6°C / ± 1.2°C (± 1.08°F / ± 2.16°F)			
	Thermocouple type E ⁽¹⁵⁾	± 0.4°C / ± 0.8°C (± 0.72°F / ± 1.44°F)			
	Thermocouple type R ⁽¹⁵⁾	± 1.2°C / ± 2.4°C (± 2.16°F / ± 4.32°F)			
	Thermocouple type S ⁽¹⁵⁾	± 1.2°C / ± 2.4°C (± 2.16°F / ± 4.32°F)			
	Thermocouple type B ⁽¹⁵⁾	± 2.0°C / ± 3.8°C (± 3.46°F / ± 6.84°F)			
	Thermocouple type N ⁽¹⁵⁾	± 1.0°C / ± 1.5°C (± 1.8°F / ± 2.7°F)			
	Thermocouple type C ⁽¹⁵⁾	± 0.8°C / ± 2.0°C (±1.44°F / ± 3.46°F)			
	Resistance	± 0.05% / ± 0.1% of full scale			
mV	± 0.05% / ± 0.1% of full scale				
Noise rejection	10Hz, 50Hz, 60Hz, 400Hz				
Step response ⁽¹⁰⁾ (0 to 100% of final value)	Smoothing	Noise Rejection Frequency			
		400Hz	60Hz	50Hz	10Hz
	None	162.4ms	249.5ms	249.5ms	1242.4ms
	Weak	317.3ms	491.5ms	491.5ms	2477.3ms
	Medium	627.2ms	975.4ms	975.4ms	4947ms
Strong	1246.9ms	1943.3ms	1943.3ms	9886.5ms	
Update time ⁽¹⁰⁾	Noise Rejection Frequency			Update Time	
	400Hz			154.9ms	
	60Hz			242ms	
	50Hz			242ms	
10Hz			1234.9ms		
Thermocouple Cold junction error ⁽¹⁵⁾	±1.5°C (±2.7°F)				

Cable	Shielded, see installation guide for details
Diagnostics ⁽¹¹⁾	Input Overflow or Underflow, sensor connection fault ⁽¹⁶⁾

Source Transistor Outputs

Number of outputs	8
Output type	Transistor, Source (pnp)
Isolation voltage	
Output to bus	500VAC for 1 minute
Output to output	None
Outputs power supply to bus	500VAC for 1 minute
Outputs power supply to output	None
Current	0.5A maximum per output
Voltage	See Source Transistor Outputs Power Supply specification below
ON state voltage drop	0.5V maximum
OFF state leakage current	10 μ A maximum
Switching times	Turn-on: 80 μ s maximum, Turn-off: 155 μ s maximum (Load resistance < 4k Ω)
PWM Frequency ⁽¹⁸⁾	O0, O1: 3kHz max. (Load resistance < 4k Ω)
Short-circuit protection	Yes

Source Transistor Outputs Power Supply

Nominal operating voltage	24VDC
Operating voltage	20.4 – 28.8VDC
Maximum current consumption	30mA@24VDC Current consumption does not include load current

Analog Outputs			
Number of outputs	3		
Output range ⁽¹⁹⁾	Output Type	Nominal Values	Over/Under-range Values *
	0 ÷ 10VDC	$0 \leq V_{out} \leq 10VDC$	$10 < V_{out} \leq 10.15VDC$
	-10 ÷ 10VDC	$-10 \leq V_{out} \leq 10VDC$	$-10.15 \leq V_{out} < -10VDC$ $10 < V_{out} \leq 10.15VDC$
	0 ÷ 20mA	$0 \leq I_{out} \leq 20mA$	$20 \leq I_{out} \leq 20.3mA$
	4 ÷ 20mA	$4 \leq I_{out} \leq 20mA$	$20 \leq I_{out} \leq 20.3mA$
	* Overflow or Underflow is declared when an output value exceeds the Over-range or Under-range boundaries respectively.		
Isolation	None		
Resolution	0 ÷ 10VDC – 12 bit -10 ÷ 10VDC – 11 bit + sign 0 ÷ 20mA – 12 bit 4 ÷ 20mA – 12 bit		
Accuracy (25°C / -20°C to 55°C)	±0.3% / ±0.5% of full scale (Voltage) ±0.5% / ±0.7% of full scale (Current)		
Load impedance	Voltage – 1kΩ minimum Current – 600Ω maximum		
Settling time (95% of new value)	0 ÷ 10VDC – 1.8ms (2kΩ resistive load), 3.7ms (2kΩ + 1uF load) -10 ÷ 10VDC – 3ms (2kΩ resistive load), 5.5ms (2kΩ + 1uF load) 0 ÷ 20mA and 4 ÷ 20mA – 1.7ms (600Ω load), 1.7ms (600Ω + 10mH load)		
Short circuit protection (voltage mode)	Yes (no indication)		
Cable	Shielded twisted pair		
Diagnostics ⁽¹¹⁾	Current – Open circuit indication Supply level – Normal / Low or missing		

Environmental	
Protection	Front face : IP66, NEMA 4X Rear side: IP20, NEMA1
Operating temperature	-20°C to 55°C (-4°F to 131°F)
Storage temperature	-30°C to 70°C (-22°F to 158°F)
Relative Humidity (RH)	5% to 95% (non-condensing)
Operating Altitude	2,000 m (6,562 ft)
Shock	IEC 60068-2-27, 15G, 11ms duration
Vibration	IEC 60068-2-6, 5Hz to 8.4Hz, 3.5mm constant amplitude, 8.4Hz to 150Hz, 1G acceleration

Dimensions		
	Weight	Size
US5-xx-TA32	0.39 Kg (0.86 lb)	Refer to the images on page 29
US7-xx-TA32	0.68 Kg (1.49 lb)	Refer to the images on page 30
US10-xx-TA32	1.08 Kg (2.38 lb)	Refer to the images on page 30

UniStream 5"

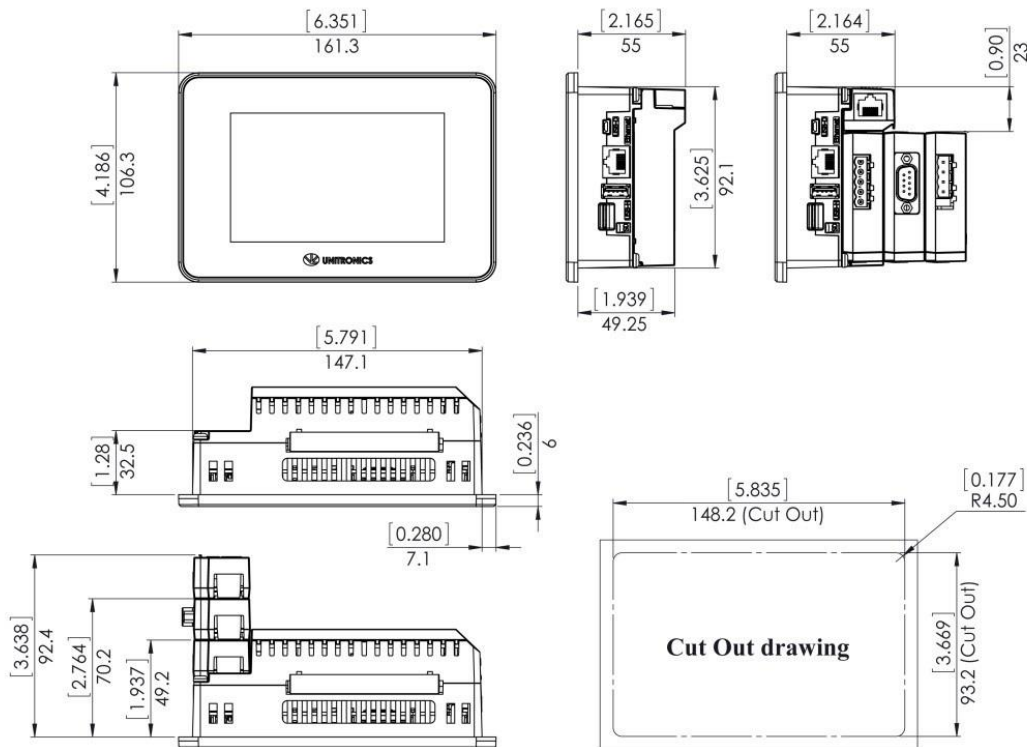

UniStream 7"

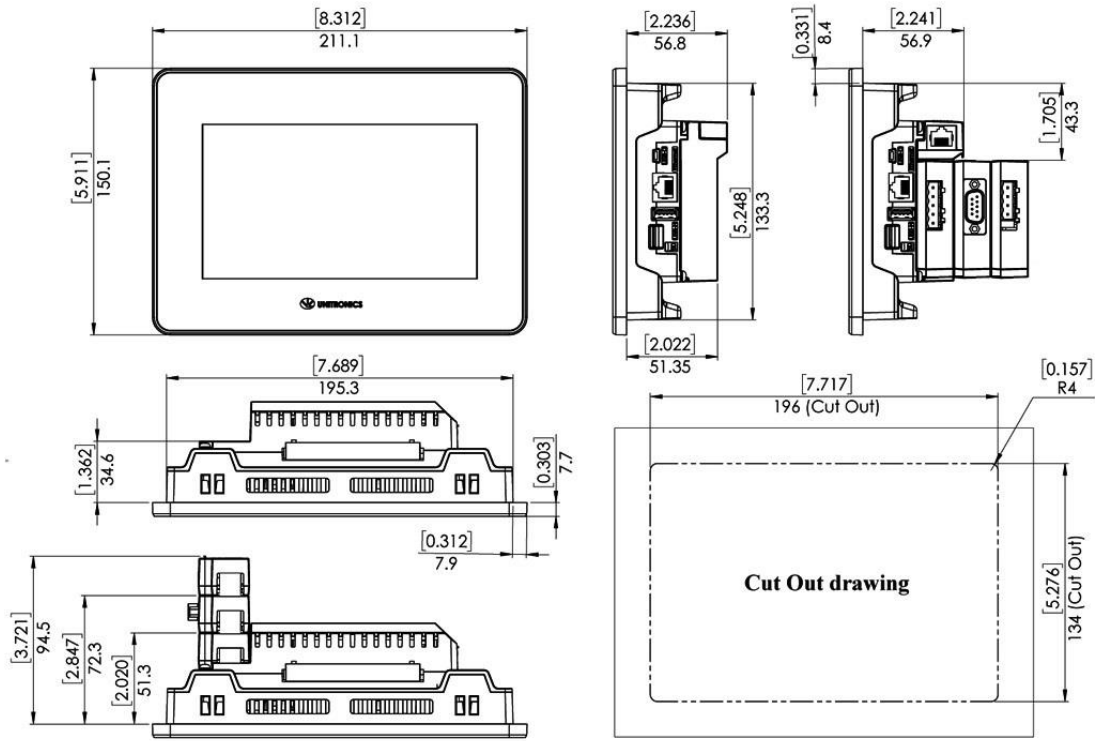

UniStream 10.1"

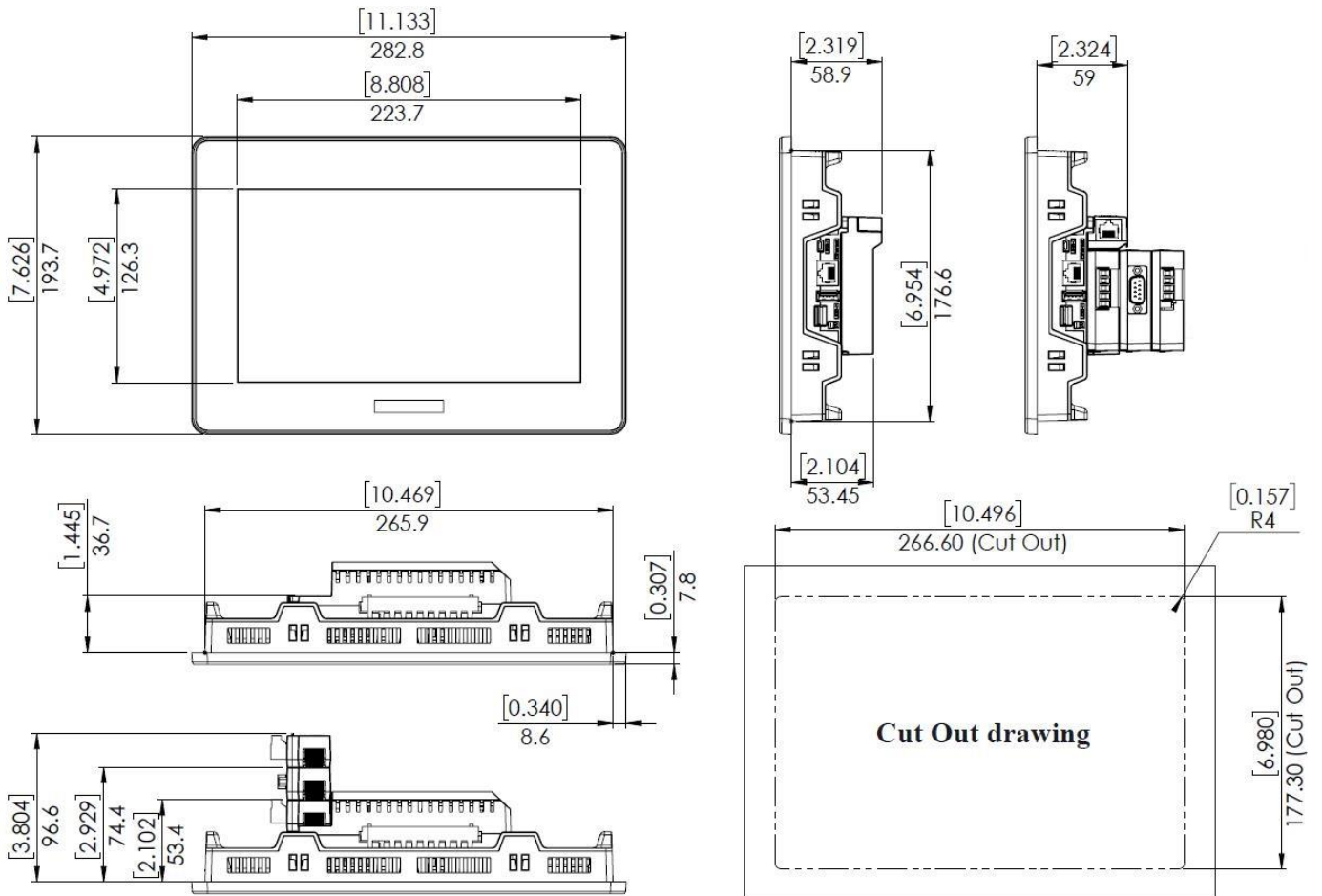

Notes:

1. Four of the digital inputs (I9-I12) may be configured to function either as normal, or as high speed digital inputs, that can receive high speed pulse signals from up to two sensors or shaft encoders.
2. Panel’s longevity is the typical operating time after which the brightness drops to 50% of its original level.
3. UAG-CX Expansion Adapter Kits comprise a Base unit, an End unit, and a connecting cable. You plug the Base Unit into the controller’s I/O Expansion Jack and connect standard UniStream Uni-I/O™ modules. For more information, refer to the product’s installation guide and technical specifications.
4. Uni-COM™ CX modules plug directly into the Uni-COM™ CX Module Jack on the back of the controller.
 UAC-CX modules may be installed in the following configurations:
 - If a module comprising a serial port is plugged directly into to the back of UniStream®, it may be followed only by another serial module, for a total of 2.
 - If your configuration includes a CANbus module, it must be plugged directly to the back of UniStream. The CANbus module may be followed by up to two serial modules, for a total of 3. For more information, refer to the product’s installation guide and technical specifications.
5. When replacing the unit’s battery, make sure that the new one has environmental specifications that are similar or better than the one specified in this document.
6. The USB device port is used to connect the device to a PC.
7. The 4-20mA input option is implemented using 0-20mA input range.
8. The analog inputs measure values that are slightly higher than the nominal input range (Input Over-range).

Note that when the input overflow occurs, it is indicated in the corresponding I/O Status tag while the input value is registered as the maximum permissible value. For example, if the specified input range is 0 ÷ 10V, the Over-range values can reach up to 10.15V, and any input voltage higher than that will still register as 10.15V while the Overflow system tag is turned on.

9. The diagnostics results are indicated in the system tags and can be observed through the UniApps™ or the online state of the UniLogic®.
10. Step response and update time are independent of the number of channels that are used.
11. Note that the diagnostics results are also indicated in the system tags and can be observed through the UniApps™ or the online state of the UniLogic®.
12. The controller inherently supports 3-wire sensors.
 4-wire sensors may be connected by utilizing 3 of the sensor wires; in-order to achieve the specified performance, all sensor wires shall be of identical type and length just as with a 3-wire sensor connection.
 2-wire sensors may also be connected; performance in this case will degrade because of the wires` resistance.
 Refer to the controller installation guide for detailed installation instructions.
13. The controller temperature inputs measure values that are slightly higher or lower than the nominal input range (Input Over/Under-range respectively).

Note that when input Overflow, Underflow or a connection fault occurs, it is indicated in the corresponding I/O Status tag (refer to the UniLogic® help for details) while the input value is registered as follows:

Fault Type	Registered Value in the Input Tag
Overflow	32,767
Underflow	-32,767
Connection fault	-32,768

14. For temperature measurement, the value is represented in 0.1° units. For example, a temperature of 12.3° is represented as 123 at the Value tag.
15. The overall accuracy for thermocouples is a combination of the per-sensor specified accuracy and the thermocouple cold junction error specification.

16. Sensor connection fault check is active by default for temperature, resistance and mV measurements. This may interfere with some test equipment like RTD, thermocouple, resistance and voltage simulators and thus may induce reading errors or cause malfunction of the test equipment and/or the controller.

In order to interoperate correctly with such equipment, you may set the Disable Fault Detection I/O tag. This will disable connection fault check for all inputs.

Note that when this tag is set, the controller will not check, or report, connection faults; thus, the reading in such case is unpredictable.

17. Life expectancy of the relay contacts depends on the application that they are used in. The product's installation guide provides procedures for using the contacts with long cables or with inductive loads.
18. Outputs O0 and O1 can be configured as either normal digital outputs or as PWM outputs. PWM outputs specifications apply only when outputs are configured as PWM outputs.
19. The controller analog outputs are able to output values that are slightly higher or lower (if applicable) than the nominal output range (Output Over/Under-range respectively).

The information in this document reflects products at the date of printing. Unitronics reserves the right, subject to all applicable laws, at any time, at its sole discretion, and without notice, to discontinue or change the features, designs, materials and other specifications of its products, and to either permanently or temporarily withdraw any of the forgoing from the market.

All information in this document is provided "as is" without warranty of any kind, either expressed or implied, including but not limited to any implied warranties of merchantability, fitness for a particular purpose, or non-infringement. Unitronics assumes no responsibility for errors or omissions in the information presented in this document. In no event shall Unitronics be liable for any special, incidental, indirect or consequential damages of any kind, or any damages whatsoever arising out of or in connection with the use or performance of this information.

The tradenames, trademarks, logos and service marks presented in this document, including their design, are the property of Unitronics (1989) (R"G) Ltd. or other third parties and you are not permitted to use them without the prior written consent of Unitronics or such third party as may own them.

UG_USx-TA32.pdf 10/23